



ARES Software Limited 5 Pillars of Project Controls



Industrial Experience

- **Qualifications**
 - Licentiate City and Guilds
 - HNC Mechanical and Production Engineering
 - Degree in Maths and computing
- **Experience**
 - Apprentice Mechanical Engineer
 - Factory Manager – power supply manufacture
 - **Business Development Director, Europe**

Academia

- Industrial Professor – Bath University
- Visiting Fellow – Cranfield University
- Board Member of the Manufacturing Advisory Board
- Fellow of the Association of Cost Engineers
- Fellow of the Association of Cost Engineers

5 Pillars

WBS Generation and Manag
Estimation
Schedule
Cost Management
Change Management

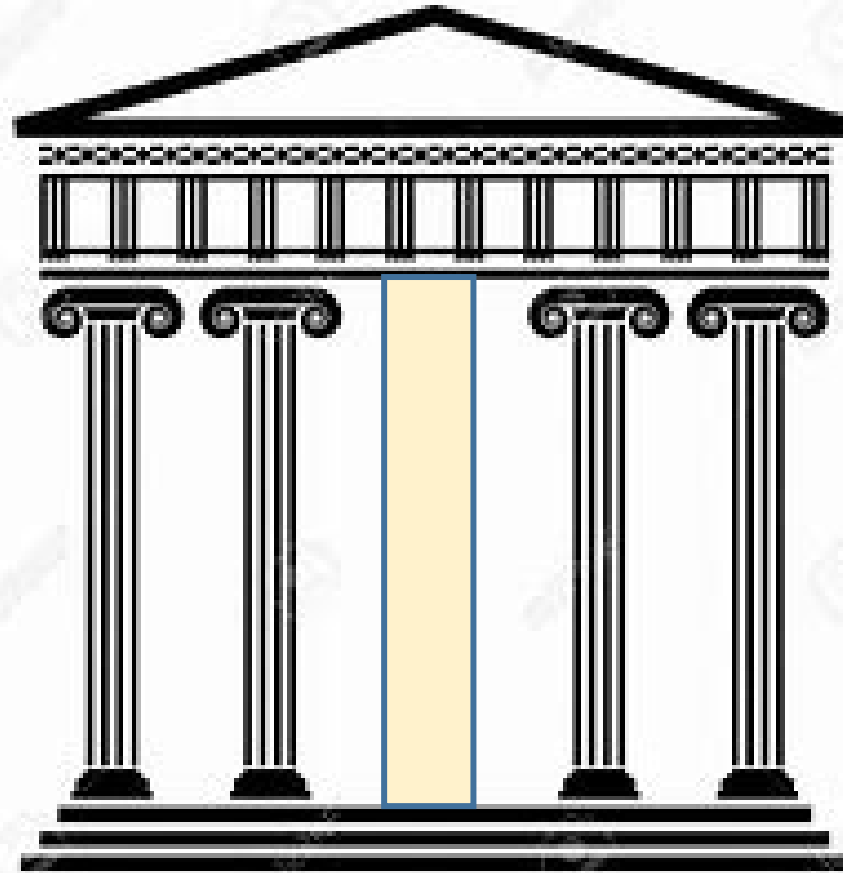

Foundations

Data
Process and governance
People

The next frontier

CAD to Cost / CAD to Plan
Measuring work done
Visualization

5 Pillars

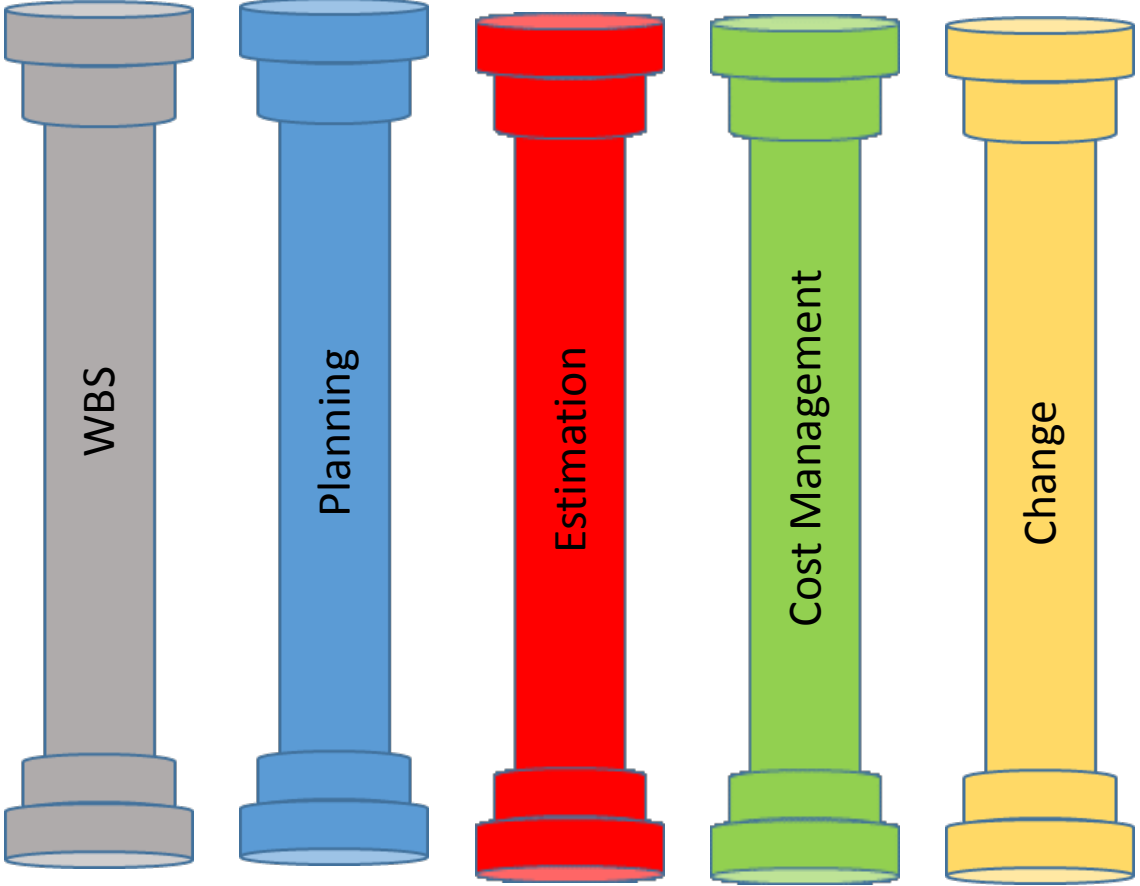

WBS Generation and Management



Originate
And
Federate

Federated WBS management



Estimation



Third party data Benchmarking Normalised Historic Project Data

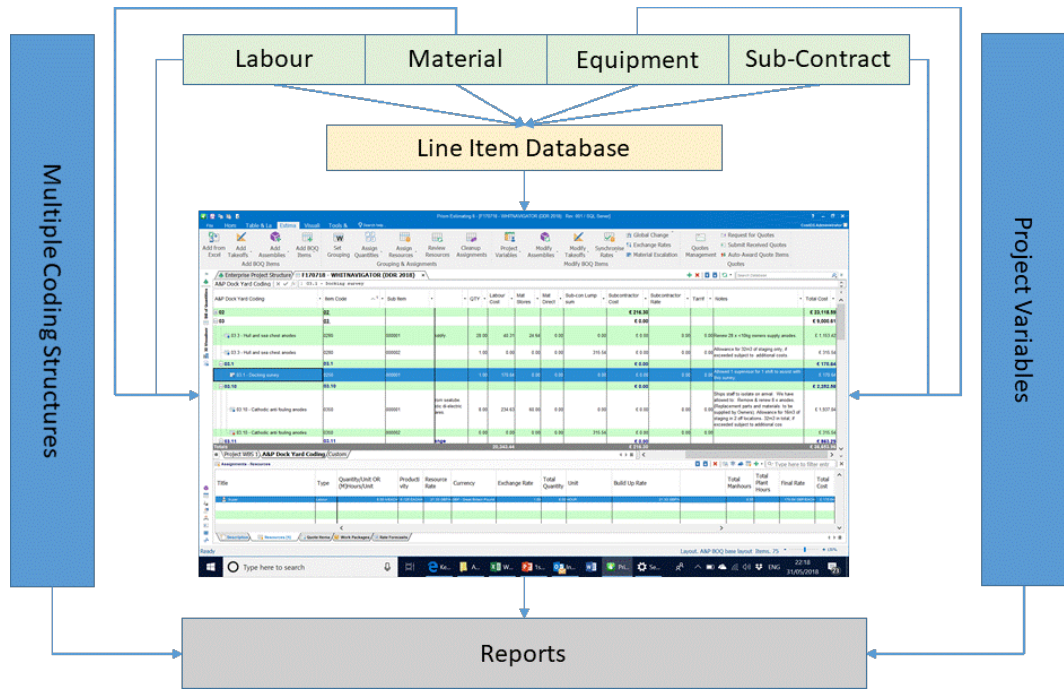

Schedule

Pray for a miracle?
Or plan for success?

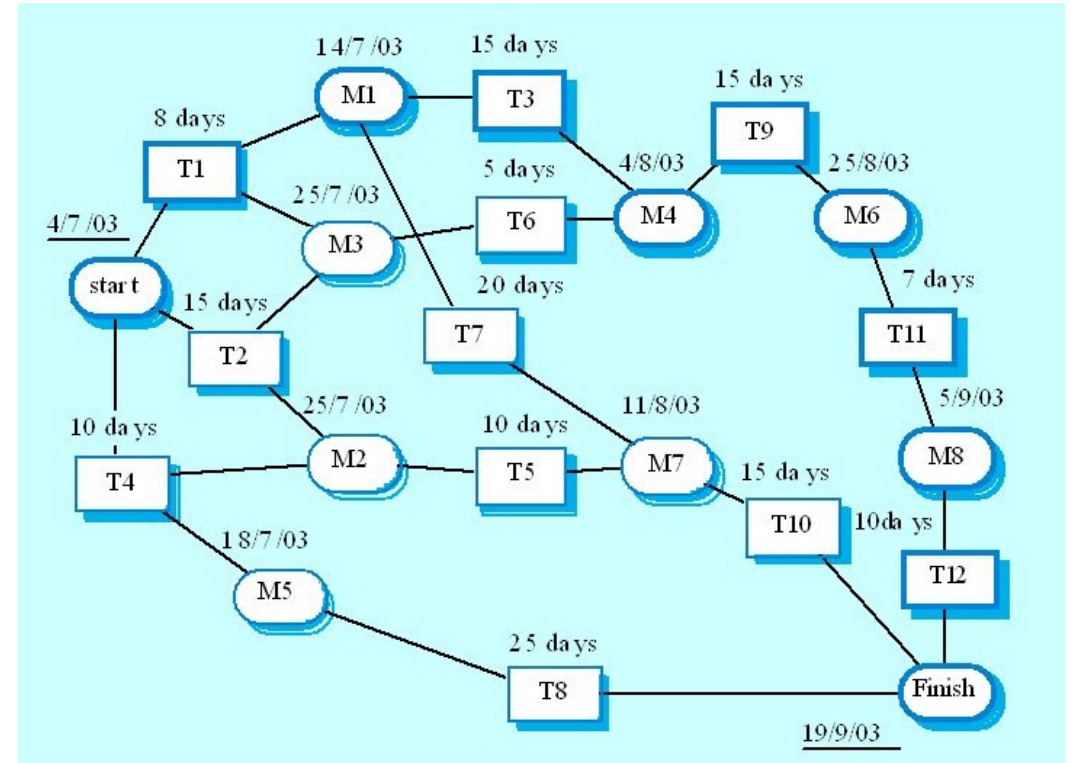
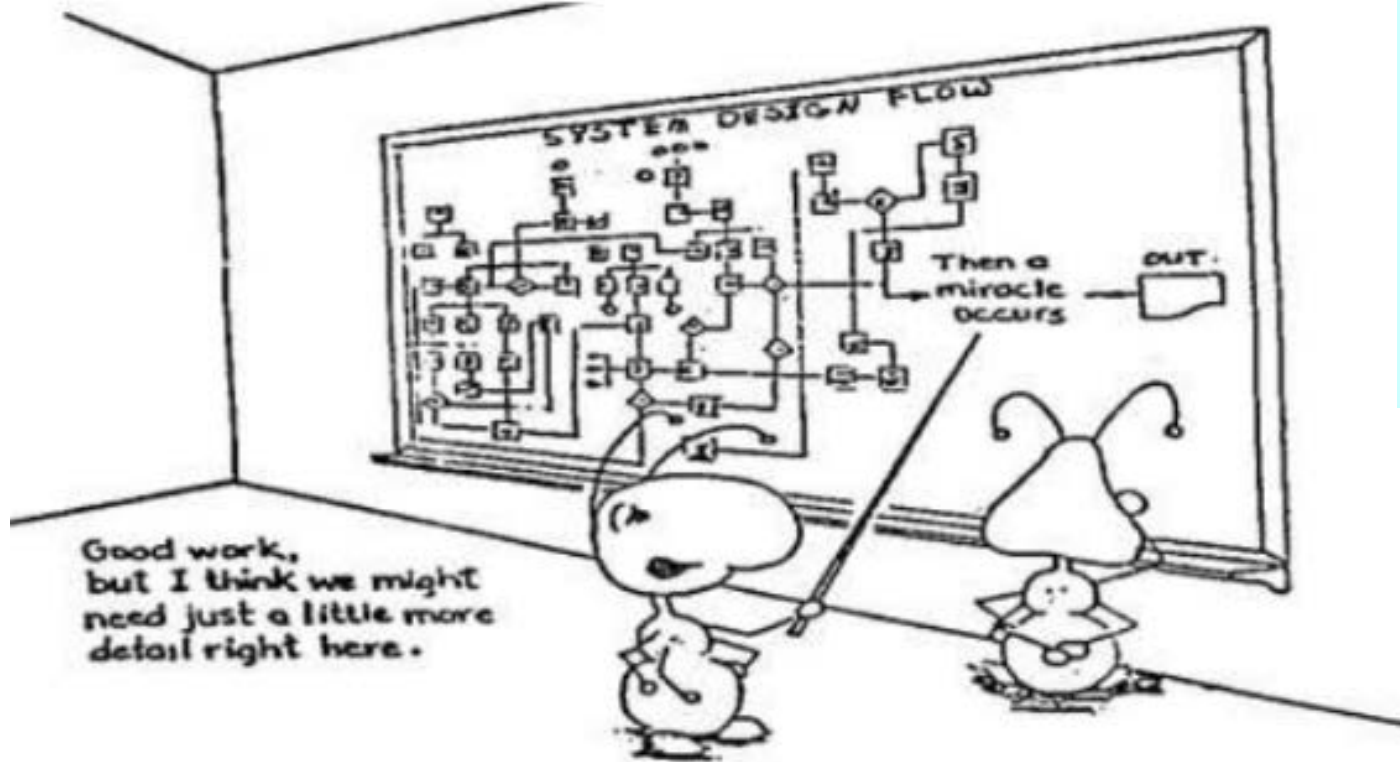

Cost Management

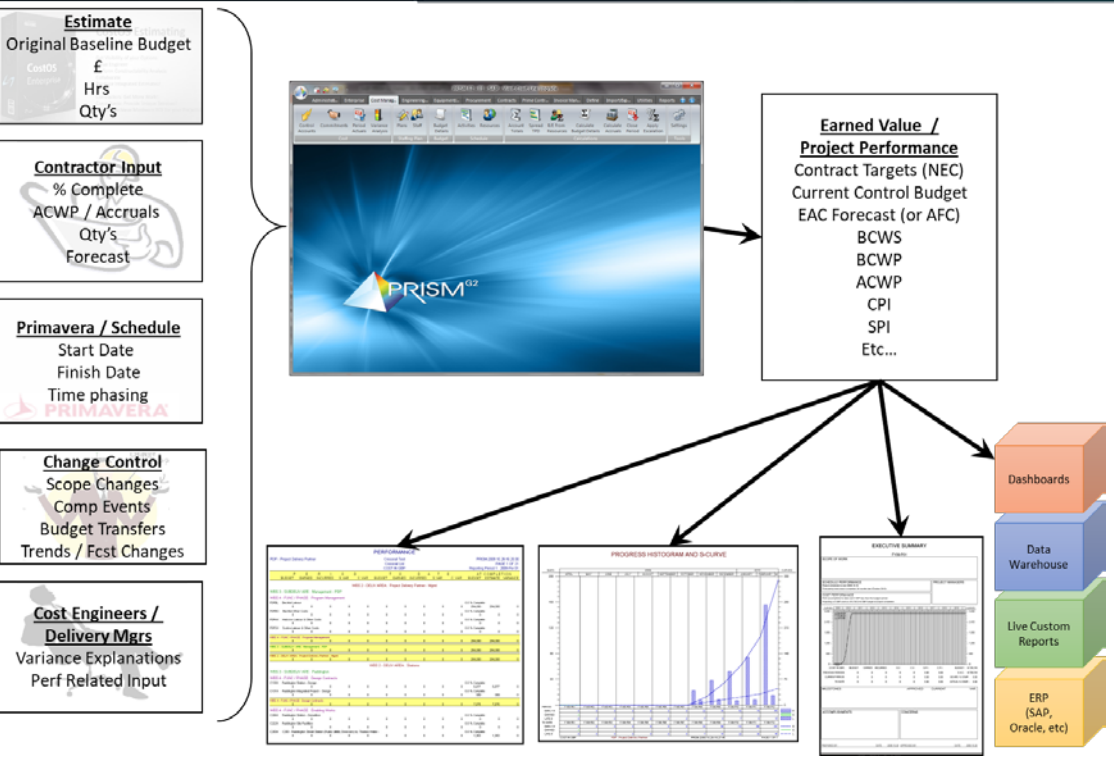

All generated from PRISM

- Project Time Phased Cost Plan
- To Date Actuals Cost of Work
- To Date Earned Value
- To Date Schedule Variance
- To Date Cost Variance
- Estimate At Complete
- Variance At Complete

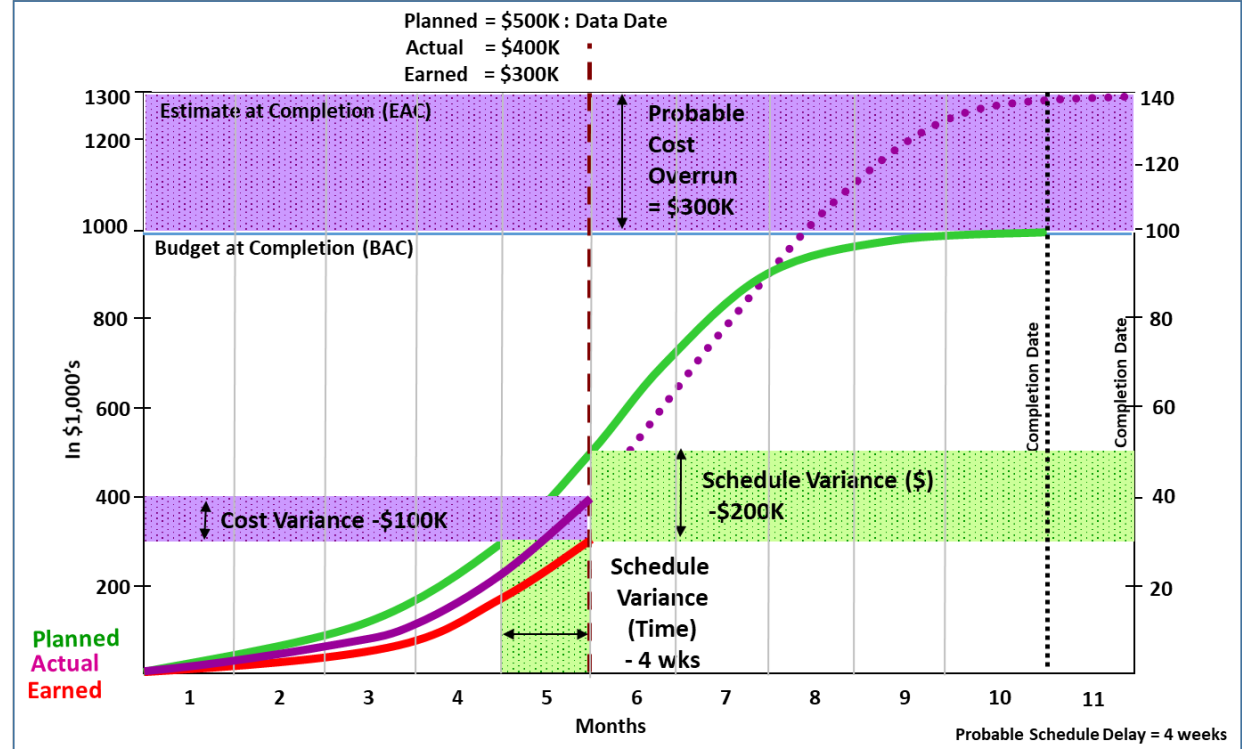

Change Management



Importance of Managing Change...



Foundations



I NARROWED DOWN THE OPTIONS TO AN ALTERNATIVE THAT COSTS TOO MUCH AND ANOTHER THAT WON'T WORK.



www.dilbert.com scottadams@aol.com

I DIDN'T DO ANY RESEARCH. IT'S MORE OF AN EXPERIENCE SORT OF THING.

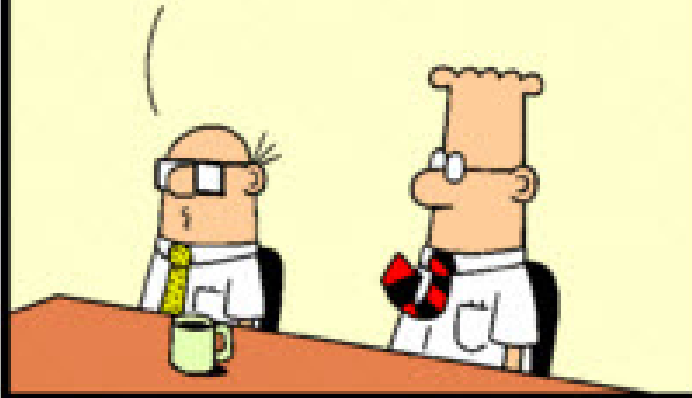

8-4-07 © 2007 Scott Adams, Inc./Dist. by UFS, Inc.

NEXT WEEK I PLAN TO THINK ABOUT THE OPTION OF USING TECHNOLOGY THAT ISN'T YET AVAILABLE.



The data to wisdom Journey

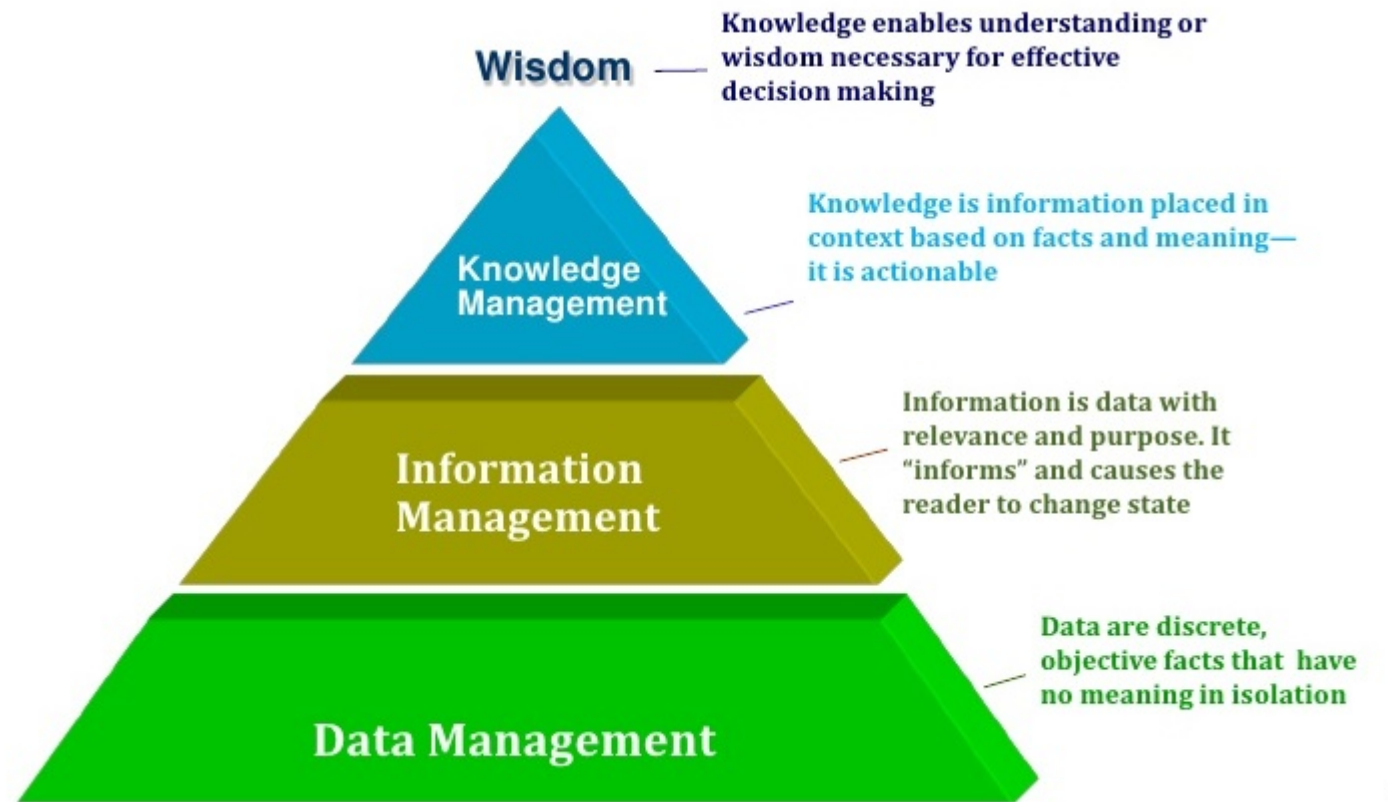

Process and governance



The next frontier

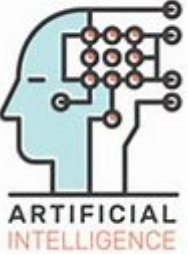
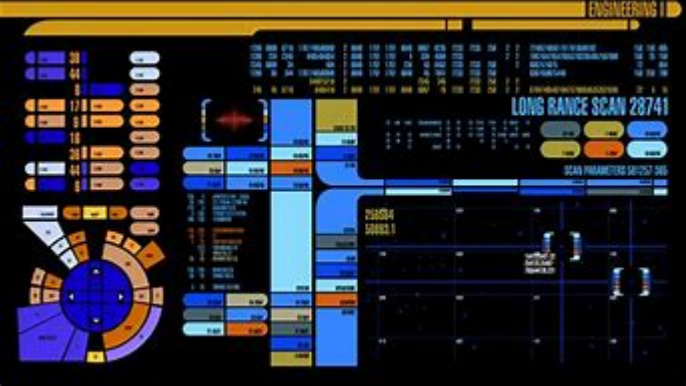

- Interpreting models
 - CAD to COST
 - CAD to Plan
- Improving forecasting
 - Machine learning
- Improving outcomes
 - AI for project management
 - *Raymond E. Levitt, John C. Kunz, Nabil A. Kartam*
 - Hagen says AI will identify true collisions versus false ones in BIM. “For new building design, AI will identify missing elements like waterproofing for specs for stadiums.”
 - *Carol Hagen*

Measuring work done (or to do)



Visualization



What Next



- Decide where the WBS originates and the level of lock down
- Estimation is challenging, start early and spiral your maturity and granularly
- Check your schedule validity early and often - speak to the cost estimators
- Find an integrated cost management that delivers early benefits
- Change is the golden thread and managing change is managing your project
- Do the simple things right all day every day

Visit us at Stand 04